



Hotwire Under Tile Heating Installation Manual

Please read this instruction manual. It includes important information that will assist you and save you time and money such as,

To calculate the wire spacing start with the M2 of the area to be heated.

Multiply this by 1000. Then divide this answer by the length of the element. The answer will be the spacing between the element runs.

**Please ensure you see page 5 for exact measurement details.*



Contents

Step 1 Read This Manual	Page 3
Step 2 Pre wire or “Rough In”	Page 3
Step 3 Cold Tail Channels.....	Page 4
Step 4 Floor Preparation.....	Page 4
Step 5 Primer	Page 4
Step 6 Cable Spacing	Page 5
Step 7 Plan the installation	Page 6
Step 8 Check the element.....	Page 6
Step 9 Tape.....	Page 7
Step 10 Roll out Element	Page 7
Step 11 Half Way	Page 7
Step 12 Nearly Finish Installing the Element.....	Page 8
Step 13 More Tape.....	Page 8
Step 14 Install the Floor Probe.....	Page 9
Step 15 Pull Cables to Power Supply Contents	Page 9
Step 16 Connect Continuity Alarm	Page 9
Step 17 Take a picture.....	Page 10
Step 18 Protecting The Element.....	Page 10
Step 19 Pour the Screed	Page 11
Step 20 Notice to Tilers	Page 11
Step 21 Connect The Thermostat	Page 11

Step 1 Read This Manual

Please read this manual. It includes everything you need to know to successfully install Hotwire.

Incorrect installation of Hotwire may lead to any warranty claim being denied.

In some States and Territories of Australia the installation of Hotwire Under Tile Heating must be performed in its entirety by a licensed electrical contractor. Whist in others a licensed contractor is only required for the connections to the thermostat. Please check with your local electrical authority or Electrical Contractor to verify the requirements applicable to your State or Territory.

The Hotwire element cannot be cut, shortened or lengthened in any way.

Hotwire kits are provided based on the M2 of the floor you are wanting to cover. (See Pg 5 for more on kit sizing.)

This element must be installed immediately under the tile. If you are wanting to install under or in a sand and cement screed you have the wrong element. Please contact your place of purchase.

Note: Water Proofing

You can install Hotwire under or on top of the waterproofing.

However please note the following,

1) Most self levelling products cannot be installed on top of water proofing. If unsure please contact the manufacturer of the brand

you are using. If you are using Ardex products you can use Arditex NA.

2) Primer is not required over most waterproofing membranes. Please speak to your tiler or waterproofer about this. Hotwire accepts no responsibility for incorrect products used in this step.

Step 2 Pre wire or "Rough In"

Three things are required before Hotwire can be installed. Please see the diagram.

1: Power supply. You will need power capable of running the Hotwire element you are installing. Eg 800 watts

2: Flush Box. A vertically flush box will need to be installed. This is a standard light switch / power point plate.

3: Draw Wire. You will need a draw wire through the wall cavity or chased into wall (if brick) and run through conduit.

Mount Flush Box Vertically.

Provide power suitable for load of element to flush box. E.g. 800 watts

Insert draw wire from flush box to floor. This will enable you to pull the coldtails to the thermostat.

NSW: (Optional in other states) Install conduit 100 mm out onto floor and 100mm into wall cavity. Run draw wire through conduit

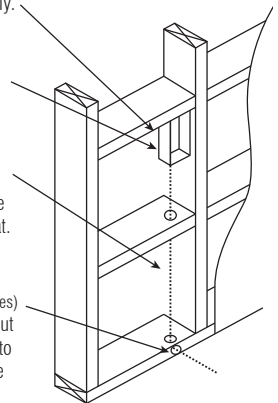

Step 3 Cold Tail Channels

To start your install process you will need to dig out two channels at a minimum of 10mm wide 150mm long and 5mm deep.

See picture below

The cold tails are conductive cables that are fitted to each end of the element. As the title says they are cold and it is this part of the cable that runs up the wall cavity. The join between the element and the cold tail is a bit thicker than the rest of the cable so you will need to dig a small channel.

Your Hammer drill or chisel should do the job, depending on the flooring. Each cold tail join must be completely fitted below the tile level. Failure to do so will void your warranty



Note:

If when cutting the grooves in the floor you need to cut into the water proofing (as in the picture), the water proofing will need to be touched up again after your work. Check with the water proofer before taking this step. They may be able to repair with a polyurethane sealant.

Step 4 Floor Preparation

The floor needs to be completely clean.

Sand, lumps of gyprock glue etc will affect your Hotwire installation. So make sure you clean the floor well. Sweep up all the dust, a once over with the vacuum is also a good idea if you have one handy.

Step 5 Primer

We prefer that you lay a 5mm thick self leveling screed over the element (more on that later). Fibre Glass mesh can also be used. However in either case the floor will need to be primed to assist the tiler.

You need to cover the floor well but keep in mind the thicker you do it the longer it will take to dry and the longer it will be before you can start installing Hotwire.

We recommend Ardex Multiprime.



Now you have the preliminaries done you can get down to installing Hotwire.

Step 6 Cable Spacing

This is really important to an excellent Hotwire installation, so please read this carefully.

Calculate the EXACT m² of the area to be heated. We don't heat under anything that is fixed. For example Vanity's, WC's in bathrooms and Kitchen Cupboards and permanent Entertainment Units in living areas.

Take the m² you are left with and multiply it by 1000 (this is to bring the measurement to square millimeters). Then divide that answer by the length of the element. This is printed on the side of the spool. The answer will be the cable spacing and should be between 50 and 75 mm. If your answer is outside this check your measurements again as you have made a mistake or have the wrong element. If this is the case do not proceed with the installation.

$$\text{Cable Spacing} = \frac{\text{M2 of floor} \times 1000}{\text{Length of Cable}}$$

The above formula is the spacing C to C (centre to centre) of the cable runs. Take a further 4 mm off your measurement for space between each run.

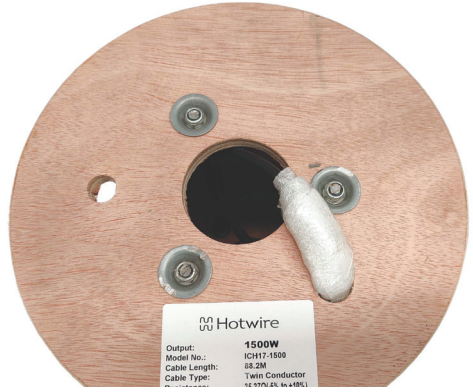

"Cable Length and Ohms reading are printed on the side of the Element"

It is a good idea to cut a jig to the size you need it rather than use a tape measure the whole time. A off cut of wood is fine, in the picture we used an off cut of electrical cable.



Note for areas over 20 m².

If your area is over 20 m² you have been supplied with two elements. These must be run in parallel and not joined together. Basically you have to install one element on one half of the floor and the other on the other half. So do the above measurement with 50% of the m².

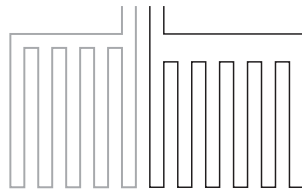

Step 7 Plan the installation

This is a step where you can come undone if you don't plan properly.

The Hotwire element must start and finish in the same place and CANNOT be cut or shortened in any way. So have a look at the room and work out what is the most logical and simple way to run the cable around that room.

You want to be doing as many long runs as possible.

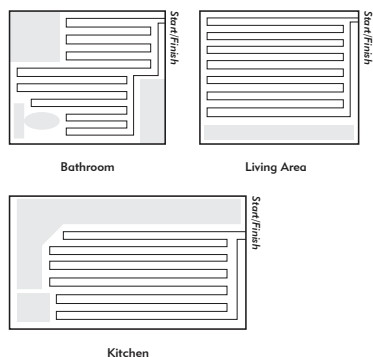

Try and leave the longest wall to last. That way if you have a little too much or too little cable left you can make an easy adjustment by coming a bit further away or going right up close to the wall. Neither option will affect the heating of the room in any way.

Step 8 Check the element

Before installing the element it is always a good idea to ensure it has not been dam-

aged during transit. We check every element before it leaves our warehouse but there is the possibility that it may get damaged by a courier.

If you have a multimeter then you can check the cable against the following table.

m2 (min)	m2 (max)	Watts*	Cable Length	Ohms	Amps
1.00	1.30	200	18	264.50	0.87
1.40	2.00	300	27	176.33	1.30
2.10	2.60	400	36	132.25	1.74
2.70	3.30	500	45	105.80	2.17
3.40	4.00	600	54	88.17	2.61
4.10	4.60	700	63	75.57	3.04
4.70	5.30	800	72	66.13	3.48
5.40	6.00	900	82	58.78	3.91
6.10	7.10	1000	90	52.90	4.35
7.20	8.90	1250	112	42.32	5.43
9.00	10.70	1500	136	35.27	6.52
10.80	12.50	1750	160	30.23	7.61
12.60	14.20	2000	180	26.45	8.70
14.30	17.80	2500	220	21.16	10.87
17.90	21.40	3000	272	17.63	13.04

If you don't have a multimeter don't panic we have you covered too.

In the Hotwire Box is a continuity alarm. It is a small black box with 3 cables coming off the end.

- 1: Remove small white sticker over "On / Off" Switch
- 2: Fix the Black clip to the Browns wire of the element.
- 3: Fix the Red clip to the Blue wire of the element.
- 4: Fix the Green clip to one end of the Green (earth) wire.
- 5: Switch the tester on.
- 6: A Red Light then shows that the tester is on and working.

7: If you have a fault the tester will start "Beeping"

If the alarm does not beep you are good to keep installing. There is also another use for the alarm so keep it handy, more about that after the element is down.

Step 9 Tape

You will need lots of bits of the cloth tape that it is included in the box.



Step 10 Roll out Element

You are now ready to start rolling out the element and sticking it down.

Stick one end in the cold tail groove you cut earlier. Do not put any part of the black cable join inside the wall cavity. It must be completely buried in the floor.

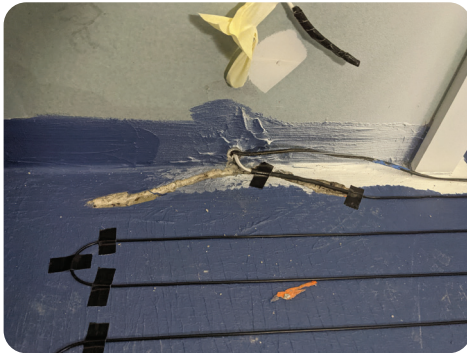

Then start spreading the element around the floor using the jig you cut earlier.

Step 11 Half Way

You will notice a half way marker. It is little piece of tape around the element. When you see this stop and look at where you are up to. If you are not sure if you are half way through the floor check your measurements. Measure the remaining m2 and use 50% of the cable length to check if you are on target.

If you are a little more or under half way you can spread the cable runs out or close them up a bit. However only do this is if the difference is a mm or 2. If it is greater than this you may need to roll the cable up and change the spacing.



Step 12 Nearly Finish Installing the Element

When you are nearly finished (only 4 or 5 meters of cable left) you will need to go in reverse. Roll off all the cable and stick the second cold tail down. Then make the remainder of the element fit in the remaining space.

You may find it necessary to make one run a little shorter or close the cables up a bit. This is Okay as long as it is not a high traffic point. In the picture you will notice the last run is a little short. This is perfectly alright as long as it is not the cable run right in front of the vanity!

If you are really stuck you can eliminate an area such as behind a door or down the sides of a Vanity unit. Just check with the homeowner to ensure they are aware so that you don't have any problems later.

Step 13 More Tape

Stick any proud bits of element down. Some of the loops may have popped up a bit. You will also need to run a strip of tape right across the whole floor to ensure the cable does not get moved when installing the leveler. Its a good idea to run tape runs every meter.

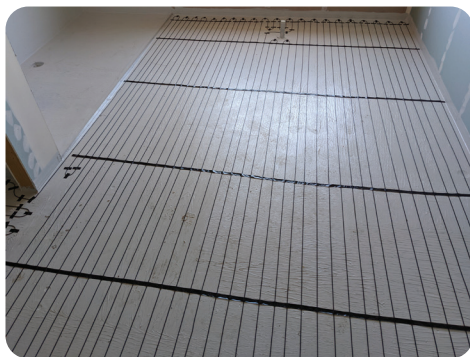
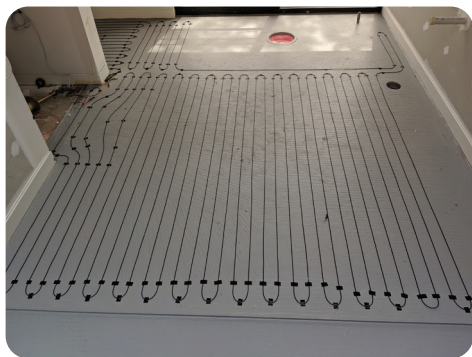
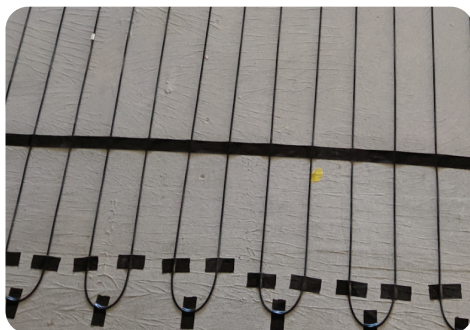

Step 14 Install the Floor Probe

You now need to install the floor probe. It should be in the box with the thermostat.

Make sure you don't stick any tape over the end of the probe. It is also critical to ensure that the probe is exactly half way between two cable runs. eg If your measurement was 60 mm. Ensure the end of the probe is 30 mm from one run of element and 30mm from another.

The Thermostat sensor should be run in a conduit so it can be easily replaced if required. Warranty claims on probes will not be accepted if not laid in a conduit.

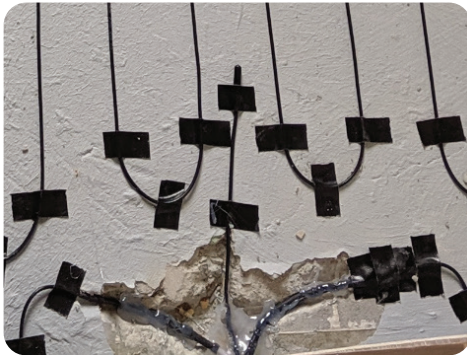

Step 15 Power Supply

Tape the ends of all three cables (each cold tail and the floor probe) to the draw wire and gently pull the cable up the wall cavity or through the conduit to the position of the power supply.

No part of the element can be run inside the

wall. The entire cold tail join must be buried in the channel you dug at the start.

Step 16 Connect Continuity Alarm

Connect the continuity alarm again. This will ensure you have not damaged the cable during installation. It will also monitor the cable while you are laying the leveling compound.

- 1: Remove small white sticker over "On / Off" Switch (if you haven't already)
- 2: Fix the Black clip to the Brown wire of the element.
- 3: Fix the Red clip to the Blue wire of the element.
- 4: Fix the Green clip to one end of the Green (earth) wire.
- 5: Switch the tester on.
- 6: A Red Light then shows that the tester is on and working.
- 7: If you have a fault the tester will start "Beeping" If there is no "Beep" you can continue with the installation
- 8: If the beep sounds at any time, before or during installation STOP IMMEDIATELY as this means that damage has occurred to the element and you will need to repair it before continuing.
- 9: Once you have finished the installation and before you start tiling reconnect the tester as above & turn on.
- 10: Keep the tester on until your tiling is complete.
- 11: If the tester light turns off you will need to replace the batteries.

It is a good idea to tape the alarm up with the tails so that it is not in your way while you finish the installation.



Step 17 Take a picture

Take a picture of the element layout. If there is ever a problem it will be handy to know how the element has been installed across the floor.

Step 18 Protecting The Element

There are two options for protecting the heating element.

- 1) The use of a Fibre Glass mesh
- 2) Covering the element with a self levelling compound.

Fibre Glass Mesh

Fibreglass mesh is available from Hotwire. Please contact our office should you need supply of this product. The product is a 1000 mm x 500 mm x 50 m self adhesive fiber-glass mesh. It is simply spread out over the element and the self adhesive backing sticks to the floor and protects the element. If using this product please ensure that you do not double one layer of mesh over

another. This will stop the tile glue getting through to the floor and may cause issues with the tiles.

Please see the following a picture of this method used see in a living area and a bathroom.



Self Levelling Compound

When using a self levelling compound we recommend you install it to a depth of 4mm so the element is just covered.

We recommend you use the same brand of levelling and tile glue. Check with the manufacturer of your Tile Glue for the appropriate levelling product that is suitable for floor heating.

Step 19 the Pour

Pour in the furthest corner from the door and work your way out of the room.

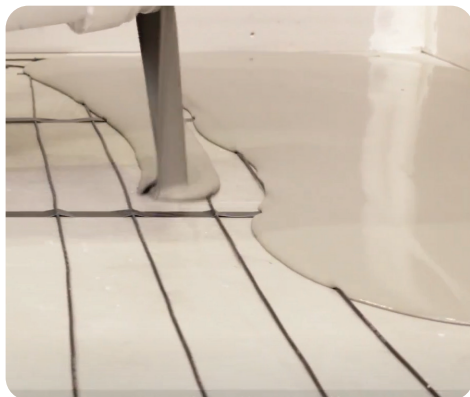

Using a flat trowel spread the leveling. It should be very easy to push and will find its own level. To protect the cable ensure you only move the trowel along the cable and not across it. You can use the top of the cables as a guide for the depth. The outline of the cables will be visible in the finished product.

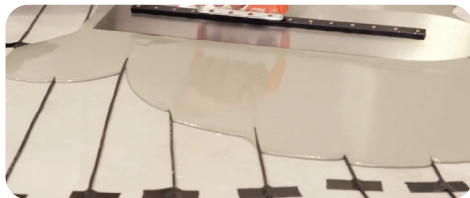

Step 20 Notice to Tilers

Inside this manual is a yellow flyer pointing out to tilers that Hotwire has been installed. Stick it to the wall in a prominent place. The flyer also has a place to write your name and number for them to call with any questions.

Step 21 Connect the Thermostat

It is a good idea to leave the continuity alarm connected during the tiling. This will ensure that any damage is noticed immediately. It will involve either a second trip to connect the thermostat or leaving the connection to the second fix electrician.

Connecting systems over 20 m2 or 3kw

Hotwire Thermostats are rated from 16 - 25 amps. Simply follow the instructions in the box with the thermostat to connect the heating elements and the floor sensing probe.

If you have a system that is over 3kw you may need to install a relay in the switch-board.

Please refer to the back of the Thermostat to confirm the capacity of the Thermostat as different models have different ratings.

We suggest installing a 30 amp relay in the switch board. Please consult your Electrician to ensure you have the right preliminary electrical work completed.

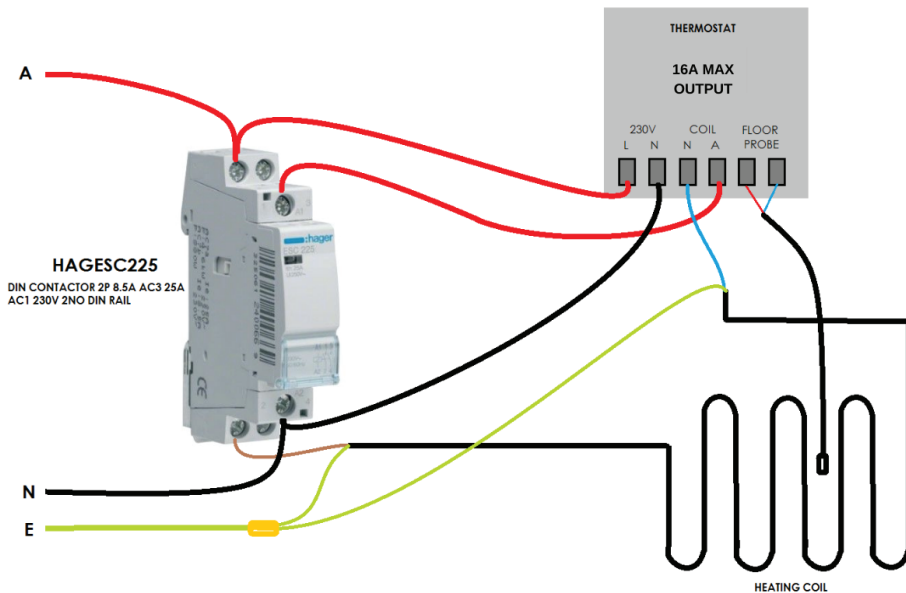

WIRING DIAGRAM FOR
1 X 32A CIRCUIT

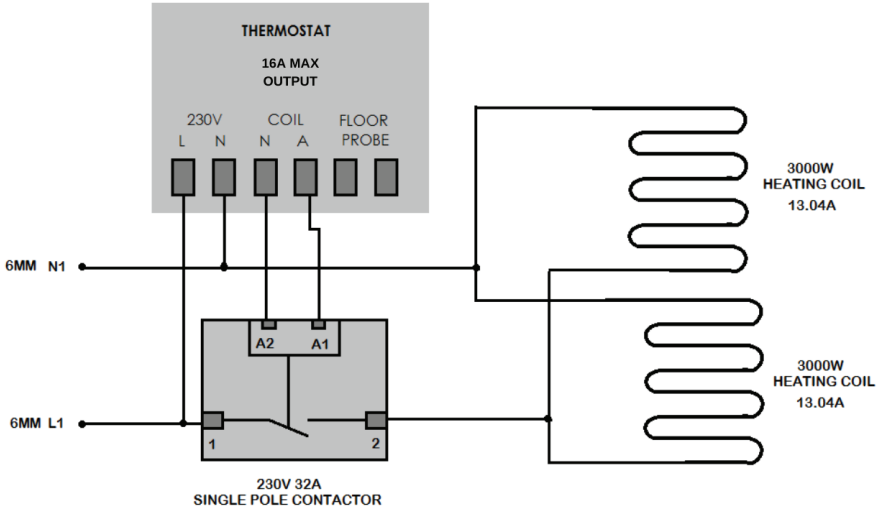

WIRING DIAGRAM FOR
2 X 16A CIRCUITS

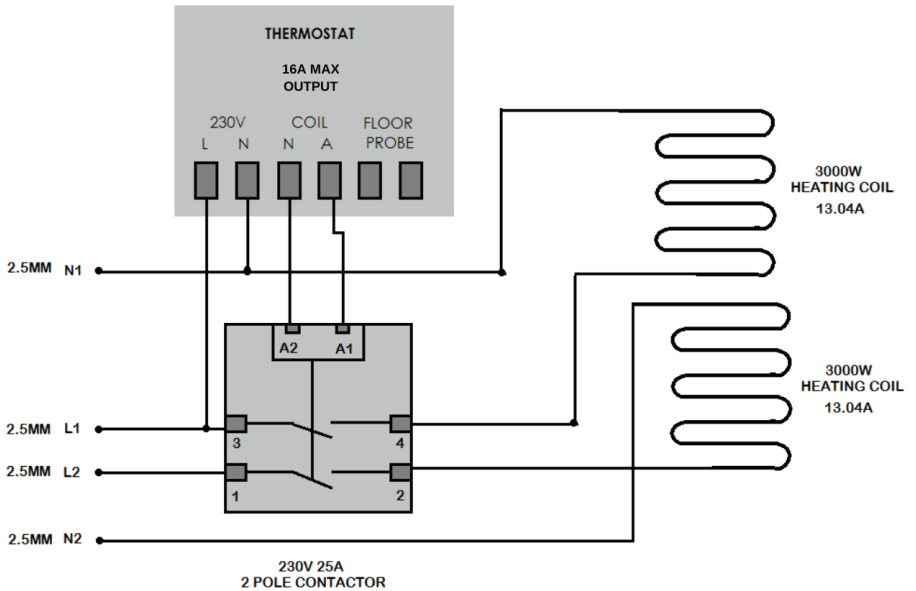

Materials Check List

Provided from Hotwire:

Hotwire Element:
Thermostat: (including a floor sensing probe)
Cloth Tape
Continuity Alarm
This Manual
Relay if required

You will also need,

Broom
Hammer Drill
Bucket
Mixer
Flat trowel
Tape Measure
Screed
Primer

Tilers instructions

It is the Tiler's responsibility to check the floor for suitability for tiling and to complete any floor preparation and waterproofing etc required before the heating element is installed.

The heating element incorporates double insulation with a multi stranded conductor and will withstand normal tiling practices. However we do ask you to note and take care of the following.

A latex modified (acrylic, PVA, SBR) cement based grout must be used, with at least a 10-15% "by weight of solid base" latex content. Wear soft soled shoes while tiling.

Ensure that enough adhesive is used to eliminate hollows or voids under the tiles.

Do not carry other work on top of the elements such as tile cutting.

Do not place ladders on the elements.

Close off the area to other trades before the tiling has taken place.

We recommend a 10mm plastic notched trowel be used to spread adhesive and that trowelling is done in the direction of the element wire. (If steel trowel is used check for any sharp edges which should be filed and removed).

Do not position tiles or other machinery on the heated floor area, and care must be taken not to drop anything.

Electrical Connection of the Thermostat

All circuit wiring supply and thermostat connection must be undertaken in accordance with the current electrical standards and regulations. The heating units must be separated from other heating sources.

The maximum thermal resistance between the heating element and the room = 0.4 m sq K/wAll electrical supply circuits must be RCD (Residual Current Device) protected with a rated residual operation current not exceeding 30 mA.

Operation

Wait 7 days for the tile adhesive to dry before you turn your heating on. Once the heating is commissioned the initial heat up time will vary depending on the sub floor type, (concrete or timber) insulation, thermal characteristics and ambient temperature. Performance will improve with use.

Do's and Don'ts

DO's

Carefully read the installation instructions prior to commencing your installation.

Check the element is working before you start.

Ensure the surface is clean and clear of obstructions.

Pre plan your element layout and stay with the recommended element spacing.

Maintain even element spacing.

Protect the heating element from damage at all times.

Plan required pre work and drilling before you lay the element.

Take care when tiling to make sure that you do not damage the element.

Ensure that enough tile adhesive is used so not to leave gaps or voids under the tiles.

DON'Ts

Don't cut or shorten the heating element.

Don't commence installation on concrete floors that are not fully cured.

Don't allow the heating elements to cross or touch.

Don't allow traffic over the heating element until the flooring has been laid.

Don't remove the heating element off the spool except during installation.

Don't store tiles sharp or heavy objects on the elements while tiling.

Don't switch on the heating until the tile adhesive has fully cured. Don't install the element over uneven floor surfaces.

Footnotes

The lowest ambient temperature that the heating element can be installed equals -80C

The minimum radius for bending the heating element equals 20 mm.

The thickness of covering materials should be at least 5mm.

Contact the manufacturer for advice if materials other than those recommended are used.

The appliance is not intended for use by young children, or infirm persons, without supervision.

Young children should be supervised to ensure they do not play with the appliance. Laws in different states and territories of Australia differ. Please check with your local

electrical authority if someone other than a licensed Electrician is able to lay the cable in your state or territory. In all states and territories all electrical connections including the thermostat must be carried out by a registered electrician.

All circuit wiring supply and thermostat connection must be undertaken in accordance with the current electrical standards and national wiring regulations.

The heating units must be separated from other heat sources.

CUSTOMER WARRANTY AGAINST DEFECTS FOR HOTWIRE UNDER TILE HEATING PRODUCTS

Turnkey International Pty Ltd (ABN 36 086 830 766) trading as Hotwire Heating (Hotwire)

This document contains the Warranty against defects for goods (Goods) supplied by or on behalf of Hotwire to the customer, whether an individual or company, (Customer), who purchased the Goods through an authorised distributor of Hotwire.

1) General:

- a) Hotwire's Goods come with guarantees that cannot be excluded under the Australian Consumer Law as set out in Schedule 2 of the Competition and Consumer Act 2010 (Cth). The Customer is entitled to a replacement or refund for a major failure and compensation for any other reasonably foreseeable loss or damage. The Customer is also entitled to have the goods repaired or replaced if the goods fail to be of acceptable quality and the failure does not amount to a major failure. What constitutes a major failure is set out in the Australian Consumer Law.
- b) The benefits under this Warranty are in addition to the Customer's other rights and remedies under the Australian Consumer Law. If the Customer is not a "consumer" or the Goods are not "of a kind ordinarily ac-

quired for personal, domestic or household use or consumption" for the purposes of the Australian Consumer Law, then to the extent permitted by law, Hotwire will not be liable for any direct or indirect or consequential loss in relation to any product defects.

- c) Nothing in this Warranty is intended to exclude or attempt to restrict or modify the operation of the Australian Consumer Law or any other applicable law that cannot be excluded, restricted or modified by agreement. For the avoidance of doubt, Hotwire's liability in connection with the Goods is limited and excluded except to the extent that the limitation and exclusion is not permitted under the Australian Consumer Law and as set out in this Warranty.

2) Installation Manual:

- a) The Hotwire installation manual (Installation Manual) is provided for the benefit of the Customer. The Goods and installation of the Goods ordinarily requires the technical skills of a qualified installer. Do not take any steps to install the Goods without a copy of the Installation Manual.

3) Installation:

- a) Hotwire recommends that the Goods be installed by a registered Hotwire Installer (Authorised Installer).
- b) Any installation by a person who is not an Authorised Installer must be carried out strictly in accordance with the Installation Manual taking into account the individual circumstances of the place of installation and a failure to do so may void or exclude the Customer's ability to claim under the Warranty.

4) Warranty:

- a) Subject to clause 7(b), Hotwire undertakes to repair or at its sole discretion to replace any part of the Goods manufactured by Hotwire which is found to have a manufacturing defect for a period of ten (10) years from the date of purchase.
- b) The period of the Warranty described at clause 7(a) does not apply to the part of the Goods comprising (or being) the thermostat and the controller. The Warranty period in relation to the thermostat and the controller of the Goods is limited to two (2) years.

5) Exclusion and Limitation of Liability:

- a) Hotwire excludes all conditions and warranties implied by custom, the general law or statute, except for:
 - i) Any implied condition or warranty the exclusion of which would contravene any statute or cause any part of this clause to be void; and
 - ii) The Warranty.
- b) The Warranty does not apply if:
 - i) Unauthorised repairs or alterations are made to the Goods;
 - ii) The Customer fails to comply with all instructions of Hotwire (whether written or verbal) in relation to the fitting, installation and use of the Goods;
 - iii) The Goods are subjected to improper voltage or power surges, misused, damaged by accident, force of nature or any other acts beyond Hotwire's reasonable control; and/or
 - iv) The Goods are improperly installed or in-

stalled other than strictly in accordance with the Installation Manual (other than where such improper or other installation is carried out by an Authorised Installer).

- v) The document entitled "Hotwire Element Testing" is not filled out correctly and supplied to Hotwire.
- vi) Proof of purchase (clearly stating the date) cannot be provided.
- c) The Warranty does not include calls to replace batteries, programme or re-programme thermostats and/or controllers, replace fuses or reset residual current devices or circuit breakers.
- d) The total maximum liability of Hotwire under the Warranty is limited to replacing the Goods, repairing the Goods or payment of the replacement cost of the Goods.
- e) Except as otherwise expressly provided in this Warranty, Hotwire will not be liable for any incidental expenses (including costs of inspection, testing, removal, reinstallation, storage or transportation), any other charges, costs or expenses of the Customer or any third party, personal injury, incidental damages, consequential losses, loss of profit, costs of business interruption, loss of opportunities or any like claims whatsoever arising from any use of, or incidental to, the Goods or their failure to operate, or arising out of Hotwire's negligence or breach of the Warranty.
- f) If any component part of the Goods is manufactured by a third party or supplied to Hotwire by a third party, any warranty offered by Hotwire in relation to the Goods or a component part of the Goods will be limited to Hotwire's right of redress (if any) against the manufacturer or supplier of the component part of the Goods.
- g) The Customer must keep Hotwire indemnified against:

- i) All claims, expenses and liabilities of whatever nature including but not limited to loss of profit, which may be made against or which Hotwire may sustain, pay or incur arising out of the manufacture or sale of the Goods to the Customer, except in so far as the same arises from Hotwire's negligence or breach of the Warranty or a proper claim under the Warranty; and
- ii) Hotwire's costs in attending to a Warranty call by a Customer which is without merit, excluded by this clause or where no Warranty is otherwise available to the Customer together with Hotwire's costs of defending any such claim by a Customer against Hotwire (including legal costs incurred by Hotwire).

To claim on this Warranty contact:

Turnkey International Pty Ltd
(ABN 36 086 830 766) trading as
HotwireHeating

Factory 1 / 7-9 Newcastle Rd
Bayswater Vic 3153

Telephone: 1300 797 060
Email: info@hotwireheating.com.au

1300 797 060
hotwireheating.com.au

Copyright 2023 Hotwire IP Pty Ltd. All rights reserved. This article may not be reproduced, distributed, or transmitted in any form or by any means, including photocopying, recording, or other electronic or mechanical methods, without the prior written permission of the copyright holder.

20-20

Hotwire (Australia Head Office)
Factory 1 / 7-9 Newcastle Rd
Bayswater Vic 3153

Phone 1300 HOTWIRE
Fax +61 (03) 8678 1337
www.hotwireheating.com.au

 **Hotwire**
FLOOR HEATING